

GGX35 Grease Guardian 230 VAC Specification (mm)

System features:

Fully automatic grease removal system with PLC controller; Dry basket solids strainer for improved hygiene; No internal user tank maintenance required; Ununiversal flow direction; Pipework and electrical connections concealed from view. Options Include: internal spray bar system, aeration system

Front View

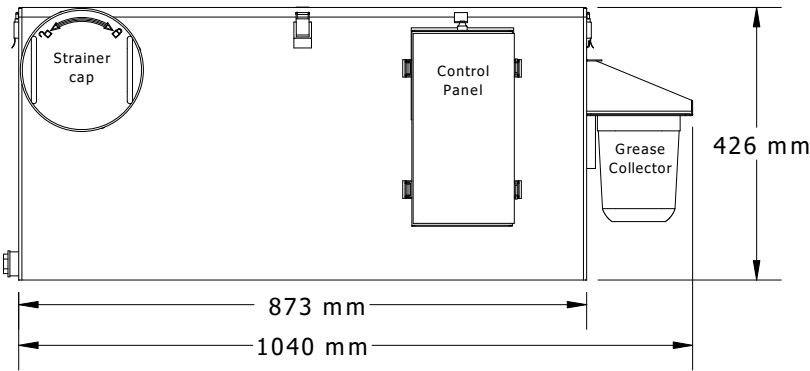

End View

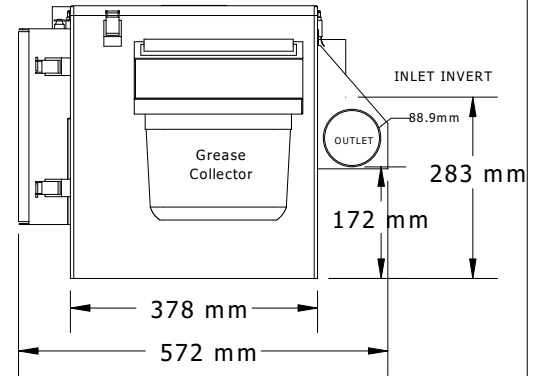

Minimum Floor-space Recommendation

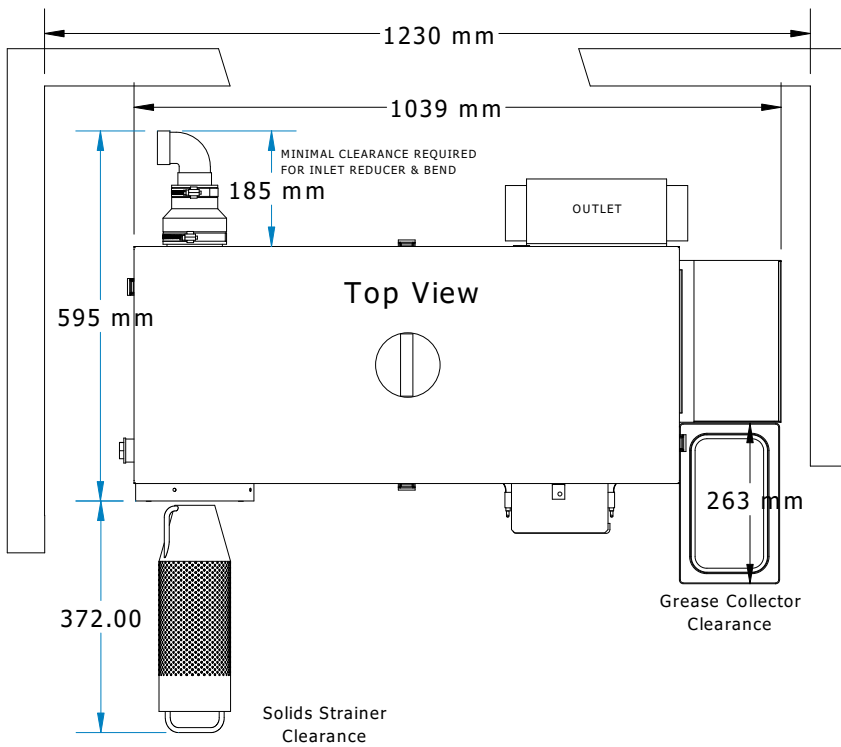

KEY INSTALLATION NOTES:

Allow for the minimum clearances shown

Allow adequate access to slide-in strainer & slide-in grease collector from front.

Inlet port is single port entry at rear. Outlet port is dual entry at rear, left/right optional

Keep outlet piping at 1:40 fall.

2 x Rubber pipe connectors are supplied, size: 3-2 inch standard. Use rubber caps as supplied for non-used ports.

Only connect mains power after filling system with water until the level stabilises

Refer to ggx manual for full installation.

TECHNICAL DATA

Weight	42.5 kg ex works
Material	Exterior, 16 gauge stainless steel, bright finish
Interior	Stainless Steel and Acetal Plastic Components
Tank Capacity	80 litres
Maximum Flow Rate	2.21 Litres per Second
Tank grease Retention Capacity	81.80 pounds (NSF verified)
Solid Strainer Capacity	6.6 pounds/2.99 kg
Skimming Rate	5 litres per hour
Programing/Control	24 hour, 7 day, multi functional digital
Electrical Load	230VAC, 1025Watts, 4.46 AMPS